



# **2022 San Mateo County Fair**

## **Rules & Regulations**

### **Handbook**

#### **Commercial Vendors**



## **Please Read Carefully & Thoroughly**

These Rules and Regulations have been established for the benefit of everyone involved in the San Mateo County Fair. By following these Rules and Regulations, we can ensure everyone an enjoyable and successful Fair.

These rules apply to all vendors, food concessionaires, and sponsors (herein after will be known as Vendor). By signing your contract for space, you are acknowledging that you have read and understood these Rules and Regulations. It is your responsibility to know and follow them. Fair Management retains the right to remove any vendor from the fairgrounds at any time without notice for reasons deemed necessary. It is important that any representative or employee working in your booth be aware of the rules set forth in this booklet. These Rules and Regulations will be strictly enforced.

Fair Management reserves the right to amend, add to, and interprets the following Rules and Regulations and to determine finally all questions and differences with respect thereto, arising out of, connected with, or related to the Fair. This handbook summarizes the rules and conditions published annually governing the use of vendor space and conduct of vendors, and it is referenced in the Agreement for Vendor Space.

This handbook is an extension of your contract with the San Mateo County Fair. You are expected to review all information provided in this packet. You are responsible for the complete compliance of the stated rules and regulations. Violations of stated policies may result in dismissal and immediate removal from the San Mateo County Fair. If you have any questions or concerns please contact the Fair Coordinators.

## **2022 Fair Information**

\*All Dates, Times and Prices listed are subject to change without notice

### General Fair Hours:

- **Saturday:** June 4<sup>th</sup> 11:00 am – 10:00 pm
- **Sunday:** June 5<sup>th</sup> 11:00 am – 10:00 pm \*San Mateo County Family PRIDE Day
- **Monday:** June 6<sup>th</sup> to be determined
- **Tuesday:** June 7<sup>th</sup> to be determined
- **Wednesday:** June 8<sup>th</sup> 11:00 am – 10:00 pm \*\$5 Admission for Adults, Juniors & Seniors
- **Thursday:** June 9<sup>th</sup> 11:00 am – 10:00 pm
- **Friday:** June 10<sup>th</sup> 11:00 am – 10:00 pm
- **Saturday:** June 11<sup>th</sup> 11:00 am- 10:00 pm \*Pacific Islands Day, Livestock Auction
- **Sunday:** June 12<sup>th</sup> 11:00am – 10:00 pm \*DIA DE LA FERIA

### General Admission Prices:

\$15.00- Adult      \$10.00-Kids (6-12)      \$10.00-Seniors (62+)

Discounts Available: **TBD \*please see website for updates**

## General Policies and Procedures

Thank you for participating in the 2022 San Mateo County Fair. Below are general policies and expectations as a vendor during our fair. Please take the time to read the full Commercial Vendor Handbook for full details.

- **Hours of Operation:**  
If the fair is open then you must be open and operating. (p.2 & 12)
- **Insurance & Valid Sellers Permit:**  
All vendors must provide proof of General Liability Insurance in order to participate. Valid sellers permit (p.17) is required to be sent in with your application. (p.12 & 13)
- **Alcohol:**  
Unless you have a current license authorizing the sale of alcohol and have been approved by the Fair to conduct limited sales, you cannot sell any alcoholic beverages of any kind at any time. You are also not allowed to consume alcoholic beverages while working within your contracted space. (p.5)
- **Booth Presentation:**  
There are guidelines and expectation for the presentation of your booth that must be followed. (p.6)
- **Outdoor Tents:**  
Outdoor commercial exhibitors are required to rent a tent from us; the rental of the tent will be on your contract. "Pop-up" and "E-Z up" tents are not allowed.
- **Booth Placement:**  
Your opinion on your booth placement is important to us, however, please know final placement is at the discretion of the Fair Coordinators and Fair Manager. (p.16)
- **Product Restrictions:**  
Certain items will not be considered for sale or giveaway. Only approved items on your contract can be sold. Details on (p.15 \*see offensive Items)
- **Customer Refunds:**  
Return policy must be clearly displayed in your booth and customer must be fully aware. (p.7)
- **Refunds:**  
Booth deposit fees are NON-REFUNDABLE. Within 30 days of the Fair any paid fees are NON-REFUNDABLE.
- **Late Fee:**  
There will be a \$100 Late Fee due if payment is received AFTER due date. (p. 10)
- **Lost passes/additional:**  
Every vendor is allotted 2 Passes per 10x10 space. Should you lose your pass there is a \$15 fee for another pass. If you require additional passes they are available for purchase (P.7 See credentials)
- **Set Up/Tear Down:**  
All vendors are completely responsible for the set up and break down of their own booths. (p.6)
- **Costumes/Dressing Up**  
Vendors may not dress up in any costumes. This is to avoid any confusion with our hired grounds entertainment.

**Please keep reading for more detailed information.**

# Index

## **A**

- Admission
  - o *Additional Passes*
  - o *Lost or Stolen Credential*

## Advertising

## Agreements

- o *Contracts*

## ADA (Americans with Disabilities Act)

## Alcohol

## Awards

## **B**

## Board of Equalization (BOE)

## Booth Regulations

- o *Presentation*
- o *Set Up/Break Down*
- o *Restrictions*
- o *Appearance*
- o *Lighting*
- o *Signage*
- o *Sound*

## Box Office

## **C**

## Cancellation

## Cleanliness

## Conduct and Appearance

## Credentials

- o Purchasing additional passes

## Customer Returns

## Cutlery Sales

## **D**

## Damages

## Deliveries

- o Future delivery of merchandise

## Drawings and Giveaways

## **E**

## Electrical

## Electrical Power Outage

## Employee Guidelines

- o Vendor Employees
- o Megan's Law
- o Work Permit Law

## Evaluations

## Expo Hall Building Temperature

## **F**

## Fair operating information

## Fees & Payment

## Fire Marshal/Safety Regulations

## First Aid

## Fork Lifts

## Food Sampling

## **G**

## Garbage & Food Waste

## Golf Carts & Scooters

## Government Regulations

## Gratuities – Tips

## Grease – Tallow & Cooking Oil

## **H**

## Helium Balloons

## Hours of Operation

## Health Department

- o Re-inspection
- o Self-Inspection
- o

## **I**

## Insurance

## **J**

## Janitorial Services

## **L**

## Layout Changes

## Liability

## Load In & Set Up

## Load Out

## **M**

## Megan's Law

## Menu and Pricing

## Merchandise

## Monetary Exchange

## Motorized Vehicles

## **N**

## Non-Profit

## **O**

## Offensive Items

## **P**

## Payments

## Plastic Bags

## Power Conservation

## **R**

## Rain

## Refund

## Returned Checks

## Restocking

## RV Accommodations

## **S**

## Sales Tax

## Screens & Fencing

## Security

## Smoking

## Solicitation

## Sound Devices/Pitches & Microphones

## Space Location

## Staffing

## State Sellers Permit

## Storage

## Sub-Leasing

## **T**

## Telephone Services

## Tents and Canopies

## **U**

## Uniforms

## **V**

## Vendor Office

## Violation Notice

## **W**

## Western Fairs Association

## Wi-Fi

# A

## Admission

Each vendor will receive 2 credentials badges per 10x10 space. These badges are valid for the duration of the Fair and include gate admission and parking. In addition each vendor will be given 13 general admission tickets for employees. If need be, 6 tickets may be exchanged for an additional badge and vice versa, 1 badge may be exchanged for 6 tickets. Badges and tickets are for EMPLOYEES ONLY! *Any vendor caught selling or giving away tickets for personal use will be cited, potentially removed from the fair and will not be allowed to participate in future fairs.*

**Re-entering the Fair:** Keep in mind that anyone who leaves the grounds during any day will need a new pass or hand-stamp to re-enter the Fair. Please remember requested number of passes is not guaranteed.

Please refer to the credential form for more information regarding credentials and admission.

- o **Additional Passes**

If you miss the deadline and still need additional admission, you MUST purchase them. Vendors may purchase them from the Vendor Office at a discounted rate:

- o \$5.00 per daily admission pass
- o \$10.00 per daily parking pass.

- o **Lost or Stolen Credentials-** The San Mateo County Fair is NOT responsible for any LOST or STOLEN credentials. You will be required to purchase replacement credentials at cost.

\*Badges are not made during Fair. If additional badges are needed you must let Fair Management know by May 20<sup>th</sup>, 2022.

## ADVERTISING

In order to maintain consistency and fairness, you are not allowed to advertise or promote your products in any location on the San Mateo County Fairgrounds or parking lots. All business is to be conducted within the booth space designated by your agreement. All marketing materials (advertising, fliers, handouts, circulars, premiums, prizes, or giveaways) need to receive prior written approval by the San Mateo County Fair. No advertising material shall state or imply that the exhibit or concession stand is an activity operated by the Fair. The San Mateo County Fair logo(s) and any other trademark artwork used by the Fair cannot be used on any marketing materials such as advertisements, promotions, or forms without written consent from the San Mateo County Fair Management.

## AGREEMENT: CONTRACT

Your Agreement is reviewed and acted upon in the best interest of the San Mateo County Fair on an annual basis. Please be aware that this handbook is made part of your Agreement, which you and your staff agree to abide by when the Agreement is signed.

## Americans with Disabilities Act - ADA

You must comply with the Americans with Disabilities Act ("ADA") of 1990 as amended, (42 U.S.C. 12101 et seq.), which prohibits discrimination on the basis of disability, as well as all applicable regulations and guidelines issued pursuant to the ADA. For more information please visit the Americans with Disabilities Act website at [www.ada.gov](http://www.ada.gov)

## ALCOHOL

Only the Event Center's on-site Master Food Concessionaire is authorized by the San Mateo County Fair to conduct alcohol sales at any time. Any and all Vendors/Concessionaires without a license and Fair approval are not allowed to bring or dispense alcoholic beverages on San Mateo County Fair property.

Vendors are also NOT allowed to consume alcoholic beverages in or near their Commercial Vendor/Concession Booth Space. Violations of this policy are grounds for removal from the property and will jeopardize future participation in the San Mateo County Fair.

## AWARDS

The Fair will be awarding special Commercial Vendors and Food Concessionaires for outstanding performances throughout the Fair. Awards will be presented before the end of the Fair, recognizing cooperation with management, courteousness to fairgoers and neighbors, booth appearance, excellent attendance, and abiding by all Fair rules and regulations. Additional awards for special programs may also be given.

# B

## Board of Equalization (BOE)

All Merchants and Concessionaires must apply for a California State Seller's Permit number directly to the BOE (State Board of Equalization). For information and seller's permit applications, call the State Board of Equalization at (949) 224-3211 or visit their website at [www.boe.ca.gov](http://www.boe.ca.gov)

## BOOTH REGULATIONS

### ➤ Presentation

We have worked hard to establish and maintain commercial vendor space design and presentation parameters that will create a festive yet professional atmosphere for our fairgoers. Your adherence to these guidelines is vital to the continued quality environment of the San Mateo County Fair. There is an established and defined difference between a Swap Meet or Flea Market and a County Fair. Set-ups and/or displays that resemble those found at a Swap Meets or Flea Markets will **not** be allowed and will be required to conform to San Mateo County Fair standards. The San Mateo County Fair reserves the right to determine what an appropriate display is.

#### ○ Inside

All in-line and corner booths located in Expo Hall will be finished with back draping and three-foot side drapes, at no charge. Drapery, including side drapes should not be altered or removed by any vendor for any reason. If your set-up does not allow for drapery, you must contact the Fair Staff to request alterations or removal of the drapery either by May 14th, 2022. If changes need to be made during set-up, changes must first be approved by Fair Management. Fair Staff will alter, remove and/or store all drapery and equipment. Please refer to diagram →

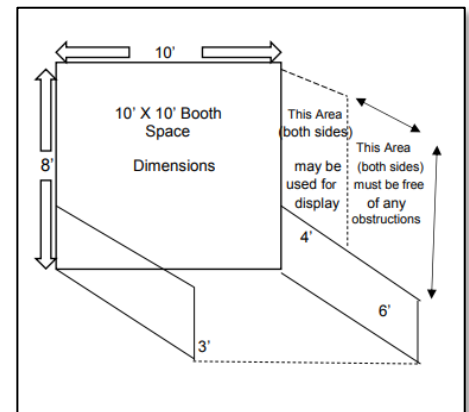

#### ○ Outdoor

All outdoor vendors are required to be in a canopy tent. The Fair will provide canopy tents with back walls and half side walls (unless otherwise noted) as well as individual lighting. Structure may be determined by location and size of booth. Outdoor booths must not exceed 12 feet in height. Any variance must be approved in writing by the Commercial Vendor Office Staff. "Pop-up" and "E-Z up" tents are not allowed.

### ➤ Set-Up/Break Down

- Vendors are solely responsible for the set-up and breakdown of their booths. Fair staff is not available to help. Equipment including but not limited to: fork lifts, dolly, push cart, tools, etc., will NOT be provided. Vendors must cone FULLY self-prepared.
  - **Dates for set up: Thursday June 2<sup>nd</sup> 2022  
Friday June 3<sup>rd</sup> 2022**
  - **If you arrive after 10:00 AM on opening day of fair you will NOT be allowed to set- up and will need to wait until the following morning to set-up.**
- Commercial Vendors are responsible for providing all other necessary furnishings, including *tables, tablecloths, chairs, carpet, wastebaskets, or any other special exhibit items you require for a professional set-up*. All materials must be fire retardant with final approval resting with the Fire Marshal or Fire Inspector.

### ➤ Restrictions

- Hanging structure counts as your display and CANNOT go over the regulated height specified in the "Indoor Section"
- Objects pin or attach, in any way, to the draperies.
- Unfinished walls exposed to public view.
- Booth space modules or furniture that are not newly refurbished.
- Booth display extending beyond the contracted space.
- Containers used for collecting tips. The San Mateo County Fair will confiscate tip jars and the contents will be donated to the San Mateo County Fair.
- Unless extra space was contracted and paid for, vendors are not allowed to utilize any space behind or around their marked booth area for booth or storage purposes.

### ➤ Appearance

- Commercial Vendors are entirely responsible for the maintenance and attractive condition of assigned space. Space must be cleaned and put in attractive condition prior to the official opening each day of the Fair. All storage of supplies, boxes, or cases must be kept from the view of the public. Commercial Vendors and Food Concessionaires may be asked to submit a detailed picture or diagram of the proposed booth or stand with the application.

### ➤ Lighting

- Use of LED lights is preferred due to brightness and low radiant heat. **NO** halogen lights permitted.

### ➤ Signage

- **ALL SIGNS MUST BE PROFESSIONALLY MADE**. Handmade or other non-professional, cardboard, paper, and/or unfinished signs exposed to public view are not allowed. Signs are not to extend over the height of the indoor back drape, which is eight feet high. No signage on top or above any booth, tent, or canopy will be permitted. The San Mateo County Fair reserves the right to relocate and/or remove any sign if deemed necessary.

### ➤ Sound

- All microphones and music are subject to approval by the San Mateo County Fair and will be controlled so they do not interfere with the public or your neighboring exhibitors and concessionaires. Please be considerate of your neighbors and do not yell or call out to fairgoers to cross the aisle.

## Box Office

The San Mateo County Fair box office is located by the Fair Administration Office at **2495 South Delaware Street** and at **Gate 5 in the East Lot**. If you need to leave admission tickets and parking passes for your employees, please leave them at Will Call by the West Gate Entrance at Delaware Street and 25th Avenue. Parking passes must be picked up before entering the parking lot.

# C

## Cancellation

30 day cancellation notice required. Any cancellation within 30days of fair will result in LOSS OF PAID FEES.

\*please note: your deposit is NON-REFUNDABLE

## Cleanliness

We take pride in keeping a well-kept appearance. The San Mateo County Fair provides janitorial service for aisles in the buildings and areas used by the public throughout the grounds. However, **it is up to you to maintain a clean booth** or stand that is always clear of debris. You are also responsible for the service, maintenance and landscaping of your assigned space. If you find an area on the grounds that appears to have been overlooked by our janitorial staff or simply does not have enough trash cans in that particular area, please let the Commercial Vendor Office Staff know as soon as possible.

**Upon load-out, please leave your booth space in the condition it was when you arrived!**

## CONDUCT AND APPEARANCE

Vendors and Concessionaires shall be solely and absolutely responsible for the conduct and personal appearance of all booth personnel. All personnel must be neatly dressed, orderly, and polite in their conduct and speech at all times. Intoxication, use or possession of any controlled substance, or impolite, discourteous or obscene speech or conduct toward or in hearing range of the public shall be sufficient grounds for immediate termination of the right and privilege to do business with the San Mateo County Fair.

All Commercial Vendors will refrain from mentioning their competitors' products in a derogatory manner or in any other way disparaging another vendor who is also participating in the Fair. Also, all aisle space is under the control of the Association and shall not be used for exhibit, demonstration or selling purposes.

Violations will be taken into consideration when reviewing applications for future San Mateo County Fairs. Employees of Food Concession Stands should be dressed in uniform with company logo or closely matching clothing such as t-shirts, shorts, aprons, or hats/visors.

## CREDENTIALS

Commercial Vendors will receive **2 badges**, which allow entrance and parking for the duration of the Fair. In addition a maximum of **13 Daily Admission/Parking Passes**. Both are at no cost and may only be used by **employees reporting to work**.

If need be, **1 badge** can be exchanged for **9 Daily Admission Passes**, but you must contact the Fair by **May 13, 2022** to make this change.

Allocation of additional admission will be determined based on need, number of employees, booth size, and past ticket counts if applicable. Remember, these admission badges, tickets, and parking passes are for employees **ONLY**. Any exhibitor caught selling tickets or giving away tickets for their personal use will not be asked to return to the Fair. Please inform your on-site staff.

- **Purchasing Additional Passes**

If you miss the deadline and still need additional admission, you **MUST** purchase them. Vendors and Exhibitors requiring additional daily admission passes for employees only, may purchase them from the Vendor Office at a discounted rate of **\$5.00 per daily admission pass** and **\$10.00 per daily parking pass**.

Please know requests made during Fair may not be granted because the number of complimentary badges, admission tickets, and parking passes are limited and are no longer created for the use of Commercial Vendors.

## Customer Returns

**All Vendor Return Policies must be clearly posted in your booth for customers to see.** Guests that need to return to the Fairgrounds to return items purchased at the San Mateo County Fair may do so by making arrangements through the Commercial & Concessions Office. The Commercial & Concessions staff will make the necessary admission and parking arrangements to ensure that the fairgoer is allowed re-entry at no personal cost. Any costs associated with admittance and parking may be charged back to the Exhibitor. Do not use your admission credentials for customer returns.

## Cutlery Sales

All cutlery must be displayed behind or under plexi-glass and not be accessible to the public. All cutlery products sold must be shipped to the customer or be sent to the Will Call Trailer outside the Main Gate for pickup.

# D

## DAMAGES

You agree to promptly reimburse and pay the San Mateo County Fair for any and all damages to Association property or equipment that you, your employees, or your agents cause during the term of your Agreement.

## DELIVERIES

Any deliveries via shipping company will be accepted by a Fair representative and available for pick up in the Vendor Office during posted hours. All deliveries will be directed to enter through **GATE 8. The Vendor Office is located on the northwest side of Expo Hall.** All golf carts and all other vehicles must stay within the parking lots and are not allowed on the fairgrounds at any time during public hours. In case of restocking during Fair hours, you must carry items in by hand or use a handcart to transport any items from parking areas or public lots to your commercial vendor location.

### U.P.S. Delivery Service

U.P.S. (United Parcel Service) will be delivering packages **June 2<sup>nd</sup> through June 12<sup>th</sup>.**

Similar arrangements have not been made with any other delivery companies, such as *Fedex or Airborne Express*. **No C.O.D.'s or other packages will be accepted by San Mateo County Fair staff without prior arrangements made** with the Commercial Vendors Office. To ensure that your packages get to you, all packages must be marked with the following address details.

U.P.S: 1-800-PICK-UPS Website: [www.UPS.com](http://www.UPS.com)

### COMMERCIAL VENDORS

San Mateo County Fair

**Booth Name**

**c/o Your Name, Commercial Vendor**

**Building: Expo Hall, Booth # \_\_\_\_\_**

2495 South Delaware Street

San Mateo, CA. 94403

### FOOD CONCESSIONAIRES

San Mateo County Fair

**Business Name**

**c/o Your Name, Food Concessions**

**Stand Name \_\_\_\_\_, Stand # \_\_\_\_\_**

2495 South Delaware Street

San Mateo, CA 94403

*\*PLEASE NOTE: GATE NAMES ARE SUBJECT TO CHANGE\**

### Future Delivery of Merchandise

If you intend to take money or the equivalent for goods or services to be delivered at a future date, you must post the following notice in a prominent location at your exhibit booth or stand:

**“The San Mateo County Fair does not guarantee future delivery of any item or return of any deposits.”**

## DRAWINGS/RAFFLES/GIVEAWAYS

If you are planning on holding a drawing, raffle, or offering giveaways, you will need to submit to the Fair Department a **detailed outline** of your drawing/raffle/giveaway with a sample of the entry left blank. This form must be submitted along with your signed contract.

Your entry may ask for *name, address, numbers, or other appropriate demographic-related information*. Please note that the drawing/raffle/giveaway is not scheduled by the San Mateo County Fair.

*A sign stating the following rule must be next to the entry box at your exhibit booth: “Need not be present to win, and no purchase is necessary.”*

All approved drawings must be held no later than **Sunday, June 12<sup>th</sup> 2022 at 8:00pm**. Holding your drawing after this deadline makes it invalid.

Solicitation for the drawing, raffle, and/or giveaway must take place only in your contracted space. Any information obtained from the drawing or raffle is to be used strictly by your business contracted with the Fair and is not to be sold, shared, or given to any other company other than the San Mateo County Fair. You must submit a letter to the Fair Department stating the winner's names, addresses, telephone numbers, and prize(s) won, no later than **June 17, 2022, 8:00pm**.

There are to be no games, gambling, or any other activity on the fairgrounds in which money is used as a prize or premium. In addition, buying back discount coupons for cash is **prohibited**. Raffles requiring the payment of money or other items of value will not be allowed under any circumstances. Only free drawings which have prior written approval by the San Mateo County Fair Management and which comply with all applicable federal, state and local statutes and ordinances will be permitted. Failure to abide by any of the above guidelines is a violation and will jeopardize your permission to conduct drawings, raffles, and/or giveaways at future San Mateo County Fairs.

# E

## Electrical

All electrical installations must conform to the Electrical Safety Code of the State of California. All electrical needs will be determined from the information provided on your completed Electrical Request Form.

- **Commercial Vendors**

One single **500 watt electric outlet** is available to all indoor commercial vendors at no charge, within a reasonable distance to all booths, and to outdoor commercial booths within 50 feet.



If you require more than a 500 watt outlet, we must be advised of the type of equipment used. Please fill out the Electricity Request Form (it is enclosed to your application).

Voltage, wattage, amperage and phase of all appliances and/or motorized equipment must be stated on the Electrical Request Form. Additional electrical requirements will be subject to availability and additional charges will be assessed before installation. All vendors requesting additional electricity will be charged only for the electrician to have the electricity ready.

**Location of space may be affected by electricity required.**

All extension cords, power strips, splitters, and plugs used must be a three wire ground system and extension cords are required to be no smaller than a #12 gauge wire.

Such non-essential devices will be removed if the total wattage exceeds the amount paid for by the exhibitor or food concessionaire.

**The San Mateo County Fair Management reserves the right to deny requests for utilities.**

**Electrical Power Outage**

In the event of an electrical power outage whereby the public utility company deems it necessary to reduce, cut, or rotate electrical services to the San Mateo County Event Center, the Event Center shall not be liable for any losses suffered by Fair Vendors and/or Concessionaires due to the power outage. Should the San Mateo County Event Center deem it necessary to cut water, gas, or electricity, the San Mateo County Event Center shall not be liable for any losses suffered by Fair Vendors and/or Concessionaires.

GENERATORS ARE ONLY PERMITTED WITH FAIR MANAGEMENT APPROVAL.

**Employee Guidelines**

The San Mateo County Fair is an equal opportunity employer, and we expect everyone we do business with to follow the same guidelines. We also strive to maintain a quality professional atmosphere. Therefore, all employees must be properly and tastefully clothed and conduct themselves in a professional and courteous manner at all times. **Each Vendor/Concessionaire is ultimately responsible for any claims, liabilities, and actions relating to the conduct and representation of their personnel.**

**Vendor Employees**

Vendor Booths and Concession Stands must be properly staffed at all times during the Fair's operating hours.

Remember, you will require breaks throughout the day and will need relief staff at your booth while you are away. Exhibitors in need of additional personnel may contact:

**Employment Development Department**

Website: [www.edd.ca.gov](http://www.edd.ca.gov)

Phone: (650) 802-5000

**Labor Ready In**

3150 Spring Street

Redwood City, CA 94063 (650) 364-8115

**Career Center placement offices at local colleges**

College of San Mateo – (650) 574-6571

Skyline College – (650) 738-4337

**Organized Labor:**

<http://www.sanmateocountyeventcenter.com/>

**Megan's Law**

Every owner, manager, volunteer and employee eighteen (18) years of age or older having access to or employment at the San Mateo County Fair & Event Center must be cleared through a Megan's Law website. The Megan's Law Form is included with every contract that has been emailed via DocuSign. It is your responsibility to complete, sign and submit this form to the San Mateo County Fair Commercial & Concessions Department. Your signature verifies that you have checked all names through one of the sites provided on the Megan's Law Form.

**Work Permit Law**

If you employ youth under the age of eighteen (18), you are required by law to see that each holds a valid work permit. You are also required to adhere strictly to all applicable child labor laws.

**EVALUATIONS**

The San Mateo County Fair strives to produce a quality, attractive, and family-oriented event for our fairgoers. With this in mind, all commercial booths and concession stands will be photographed, evaluated, and/or audited at least once during the Fair.

Evaluations are based on the general appearance of the booth or stand, management practices, personnel, and compliance with the rules and regulations outlined in this handbook. Please make sure to communicate with your employees the importance of evaluations for future participation at the San Mateo County Fair. Evaluations are available upon request and can be mailed to you after the Fair ends.

- Customer Service
- Professional Product Display and Exhibit Furniture
- Company Name and Booth Number Displayed in Booth
- Appropriate Paperwork and Payments Completed in a Timely Manner
- Operations Confined to Assigned Space
- Posted Notice of Exchange/ Refund Policy
- Conduct of Exhibitor/Conduct of Personnel
- Appropriate Attire of Personnel
- Noise Level of Microphone and Amplification Devices
- Proper Approval for Drawings and/or Microphones
- Observation of Hours of Operation
- Sale and Display of Approved Items Only (we will not permit any Commercial Vendor to sell false replicas of brand name products)

**San Mateo County Fair Evaluation**

Your comments and suggestions are important to us. A feedback form will be made available to you on the last day of Fair. We would appreciate your comments on what you think we could improve. We would also like to hear those things you think we are doing right. Please take some time to give us your comments about the Fair!

**EXPO HALL BUILDING TEMPERATURE**

There is air conditioning in Expo Hall which will be activated at the discretion of Fair Staff. Please be advised that due to the many open doors throughout the building the temperature does not remain constant.



**FAIR OPERATING INFORMATION**

**Address:** San Mateo County Event Center  
 2495 S. Delaware St.  
 San Mateo, CA 94403  
 Phone: 650-574-3247  
 Fax: 650-574-3985

**Main Parking Lot Address**  
 1346 Saratoga Drive  
 San Mateo, CA 94403

**Web:** [www.SanMateoCountyFair.com](http://www.SanMateoCountyFair.com)

**General email:** fair@smcec.co

**Administration Office Hours during Fair:** 8:00am – 6:00pm

<b>Staff:</b>	
Dana Stoehr	<i>Chief Executive Officer</i>
Diane Baumann	<i>Controller</i>
Justin Aquino	<i>Fair Operations Manager</i>
Kerry McArdle	<i>Fair Coordinator</i>
Nesh Pal	<i>Parking &amp; RV Supervisor</i>

**Fees & Payments**

Full payment is encouraged. However, 25% of the base cost is non-refundable and required with a copy of the signed agreement for space reservation (other fees may apply). Balance due is payable on or before the deadline date stated in the contract. Failure to pay on time will result in cancellation of the contract by Fair Management. No checks will be accepted after May 13, 2022. Cash, money order, Visa/MasterCard/American Express, or cashier's check only will be accepted after this date payable to San Mateo County Fair.

A \$25.00 administrative fee will be charged for lost contracts or for any check returned for any reason. A \$75.00 administrative fee will be charged for approved contract changes. Vendors shall pay all required fees, taxes, and deposits and shall be responsible for other city, county, and state permits and licenses required by law. **Any payments made after June 4, 2022 for the 2022 Fair will incur a \$100.00 late fee.**

**FIRE MARSHAL/SAFETY REGULATIONS**

The Health and Safety Code of California will govern all exhibits. The following guidelines are provided for your convenience, but there is more information regarding applicable regulations. For a complete listing of State Fire Marshal regulations, please visit the website: <http://osfm.fire.ca.gov/sfmfirecagov.html>

- The San Mateo Fire Marshal may enter any portion of any commercial vendor booth or concession stand on the grounds of the San Mateo County Event Center at any time for the purpose of inspecting the premises for fire and life safety. **ALL BOOTHS WILL BE INSPECTED AND MUST BE APPROVED BY THE FIRE MARSHAL PRIOR TO THE FAIR OPENING.**
- No display or exhibit may be installed or operated that will interfere in any way with access to any exit or with the visibility of any exit sign.
- No display shall block access to firefighting equipment, such as fire extinguisher stations, fire alarms, pull stations, fire hose cabinets, and fire hydrants.
- No display, exhibit, booth, or temporary construction shall be built of highly combustible material.
- Any paper, fabric, or decorative materials used in displays or exhibits must be fire resistant or treated with an approved fire retardant solution prior to use. **UNDER NO CIRCUMSTANCES MAY CREPE PAPER BE USED.** All draped, hanging curtains and other decorative material, including Christmas Trees, that would tend to increase the fire and panic hazard must be made from non-flammable materials or treated and maintained. Documentation of flame – retardant products used must be maintained.
- Hazardous processes, displays, or demonstrations will be required to provide portable fire protection, (i.e. properly anchored fire extinguisher).
- Electrical equipment and installation will be inspected and approved by a qualified person. All electrical installation shall conform to the

Electrical Safety Code of California.

- The use and handling of any flammable or combustible liquid will be subject to approval by the San Mateo Fire Marshal.
- All compressed gas cylinders (i.e. helium tanks, propane tanks, etc.) must be secured with a chain(s) to a permanent structure to avoid tipping. A "No Smoking" sign must also be posted where cylinders are stored. Please notify the Commercial Vendor Office if you intend to use any type of tank.
- Cooking performed by a commercial vendor may be allowed only in approved locations with approved equipment. Notify the Commercial Vendor Office if you intend to cook within your commercial booth.
- The use of any type of open flame must be approved by the San Mateo Fire Marshal.
- All motor vehicles on display shall have battery cables disconnected and taped, and fuel tanks must be provided with locked caps or sealed in a manner approved by the San Mateo Fire Marshal. Fuel tanks should be no more than one-fourth full at all times.

**For questions regarding Fire Regulations at the San Mateo County Fair, contact:**

San Mateo Fire Department 1900 O'Farrell, Suite 140 San Mateo, CA 94403 650.522.7900 or [www.ci.sanmateo.ca.us](http://www.ci.sanmateo.ca.us)

## FIRST AID

First Aid will be available during all hours of the Fair at the First Aid building located across from Redwood Hall.

## Forklifts

If you need a forklift, you will need to make arrangements on your own as the San Mateo County Fair does not provide forklift equipment.

## Food Sampling

If you are selling or handing out samples of prepared or prepackaged food products, you must follow all guidelines outlined in this book and set by any governing agency. Food samples are subject to review and approval on a per case basis by The San Mateo County Fair. Beverage samples are limited to a two (2) ounce serving or package. Alcohol sampling is not allowed.

# G

## Garbage/Food Waste

Please do not throw or sweep rubbish into the aisles. Bring your own trash bin to be used within your contracted space or use the trash bins that are provided for this purpose in or near all exhibit areas and buildings. Those demonstrations that require food must provide their own, clearly marked trash bins. These must be large enough to handle a full day's operation. All bins must be emptied each night for early morning pick up. Trash barrels placed behind or near concession stands should be used, rather than the trash barrels located in the highly visible dining and shopping areas, which are intended for the use of Fair guests.

## GOLF CARTS AND SCOOTERS

To ensure safe fairgrounds for the public and all employees, the following safety guidelines apply to all electric and gas golf carts and scooters. Only carts with permits will be allowed to operate on the grounds and shall comply with the following:

- Permit and number must be prominently displayed (permit application enclosed).
- All carts must be insured for a minimum of **\$1,000,000.00** in general liability insurance. Your certificate of insurance must specifically state golf cart coverage and be written to the specifications of CFSA Insurance Statements.
- In our efforts to provide a safe environment for our patrons, vehicle access during the public hours of the Fair is limited to emergency or essential movement.
- Carts must be operated by responsible, licensed drivers (minimum age 18) at safe, reasonable speeds.
- Every effort to keep carts out of public areas during operating hours is encouraged. Please consider the need to drive a cart through public areas.
- Pedestrians ALWAYS have the right away over carts. **Drivers are not to honk the horn or tell people to get out of the way.**
- No open alcoholic containers are to be on any cart, nor shall any driver be under the influence of drugs or alcohol. Carts of violators may be impounded for the duration of the Fair and future contracts or privileges be placed in jeopardy.

## Government Regulations

Your commercial vendor booth or concession stand must be conducted in a manner that strictly conforms with all applicable laws of federal, state and local authorities; public safety and fire regulations; and rules and regulations of state and local health authorities.

You must also obtain all licenses applicable to the operation of your commercial vendor booth or food concession stand and are responsible for any other city, county and state permits and licenses required.

## GRATUITIES

Gratuities of any nature to any San Mateo County Fair employee or officer should **not be requested nor offered**. **Further, you are not allowed to solicit gratuities or tips from fairgoers.** Any "tip jars" will be confiscated by the San Mateo County Fair representative and the contents will be donated to the Fair.

## GREASE/TALLOW/COOKING OIL

Several grease bins will be provided by the Fair. All cooking oil should be disposed of in these containers. If the grease bin is full, find the next closest available grease bin. Do not place grease in cardboard boxes or any other container that is not intended for that purpose. **DO NOT POUR GREASE INTO DRAINS.** Notify the Fair Coordinator at the Commercial Vendor Office in Expo Hall if bins are full or call [\(650\) 574-3247](tel:6505743247) (ask to be transferred). Violators will be fined and charged for cleanup.

## Helium Balloons

Helium balloons may not be distributed or sold inside or outside the facility. With the prior approval of The San Mateo County Fair, helium balloons may be used when they are permanently affixed to a booth display. If helium balloons are released for any reason within the facility, labor and equipment costs associated with the removal of the balloons from ceilings shall be charged to the Renter. Additionally, helium balloons may not be released into the outside environment from the premises of The San Mateo County Fair.

## Hours of Operation

The San Mateo County Fair hours of operations is listed at the front of this handbook. You will also receive a Fair Schedule of Events and Discounted Days. Please note the days and times for loading in and out. Know that if your items are not removed from the property by 10 AM on the final load out day, your items are subject to being thrown out and donated.

You are required to be open all hours of the San Mateo County Fair. Daily maintenance, restocking and preparations are to be completed each day prior to opening of the San Mateo County Fair.

## Health Department

If you are selling or handing out samples of prepared or pre-packaged food products you must follow all guidelines outlined in this book as well as those set by any governing agencies.

Your booth and stand must be manned and staffed at all times, and there must be a person of authority, such as the owner or manager, on the premises while the Fair is open to the public.

### → Re-Inspection

**If you fail your initial Health Department inspection, you may be asked to close by Fair Management until a re-inspection is made.** If you fail your re-inspection or are cited for any critical violations, your stand may be closed for the duration of the Fair and the location assigned terminated as well as your stand removed. Critical violations are those that compromise public health resulting in food-borne illness if not corrected immediately.

### Common critical violations include:

- Temperature violations such as insufficient refrigeration or improper cooling or heating procedures
- Lack of cold or hot water
- Surfacing sewage
- Cross connection of potable water and sewage
- Improper food handling and/or storage procedures
- Cross contamination
- Hand washing sink inaccessible or lacking soap and paper towels
- Insect or rodent infestation
- Gross unsanitary conditions

For more details and questions regarding Food Handling, Health Regulations, Forms and Fees at the San Mateo County Fair, please contact: **COUNTY OF SAN MATEO ENVIRONMENTAL HEALTH SERVICES**

455 County Center, Redwood City, CA 64063  
 Phone: (650) 363-4305 Fax: (650) 363-7882

### → Self-Inspection

Self-inspection forms supplied on the Health Department's website are to be filled out and posted in all food concession stands prior to your health inspection.

## Insurance

### General Liability

All **Commercial Vendors, Concessionaires & Sponsors are required to fulfill the insurance requirement** one of 3 ways:

- 1) Provide the Fair with an original Certificate of Insurance in the amount of **\$1,000,000.00** General Liability by the date specified on the Agreement for Exhibit Space. (*Hazardous Exhibits, Attractions, & Events require a coverage amount of \$2,000,000.00*). **All certificates *MUST* list the following additional insured statement: "June 4<sup>th</sup>-June12th, 2022 The State of California; The San Mateo County Exposition and Fair Association; California Fair Services Authority; San Mateo County; entities (public or non-profit) operating as California designated agricultural fairs; their agents, directors, officers, servants, and employees are made additional insured, but only insofar as the operations under this contract are concerned."**

Certificate Holder: The San Mateo County Exposition and Fair Association

2) Purchase Commercial General Liability insurance coverage for June 2, 2022 – June 13, 2022 by sending a \$135.00 payment made out to San Mateo County Fair. Please note: **No personal checks will be accepted. No company checks will be accepted three weeks prior to the Fair.**

3) Include your CFSA master list insurance number on the bottom left corner of your signed contracts.

The Certificate of Insurance must be submitted with your signed contract and deposit. If you purchase insurance after **May 18, 2022**, a **\$15.00 late fee will be charged**. If any one of the three items listed above is not provided to the Commercial Vendor Office by deadline specified on the contract, you will be required to purchase insurance from CFSA and you will be charged \$135 automatically.

## Worker's Compensation Insurance

It is your responsibility as an employer to comply with California state law and obtain Workers' Compensation Insurance for all employees, unless you do not hire employees and staff your operation only with owners, partners, or immediate family members.

For detailed information regarding California State Workers "Compensation Insurance, Labor Laws, and Safety Information", please contact:  
**The Department of Industrial Relation                      Wages, Hours and Working Conditions                      Worker's Compensation**

[www.dir.ca.gov](http://www.dir.ca.gov)

Office of the Director  
455 Golden Gate Avenue  
San Francisco CA 94102

Division of Labor Standards Enforcement  
Minimum wage hotline

(888) ASK –WAGE / (888) 275-9243

Division of Workers Compensation

Public Assistance

(800) 736-7401

### Occupational Safety and Health

Division of Occupational Safety and Health

Consultation service for employers  
(800) 963-9424

### Public Information Office:

(415) 703-5070



## Janitorial Services

The San Mateo County Fair provides janitorial services for aisles in the buildings and areas used by the public. However, it is up to you to always maintain your booth clean and clear of debris. You are also responsible for the service, maintenance and landscaping of your assigned space. For more information, see Cleanliness.



## Layout Changes

Due to unexpected grounds layout changes, Vendors may be required to set-up or move to a new location other than that stated on your contract. Should you be required to move, you will be notified as soon as possible. Each vendor and food concessionaire agrees to cooperate, at no cost, with any and all requests to re-locate made by Fair Management. **No refunds will be issued due to a relocation issue.** The Association reserves the right to relocate any exhibit at any time for the betterment of the show.

## Liability

The San Mateo County Fair is not responsible for the loss or damage to vendor property during the term of June 2022 (**dates include the fair dates June 4-12 2022, plus set-up and load-out dates**) and shall not be held responsible for any injury to person or persons of the exhibitor and or concessionaire, its employees or agents from any cause whatsoever arising from the performance of their contract.

## Load In and Set Up

Commercial Vendors may begin moving in 2 days before Fair. *[Thursday, June 2 2022 8:00AM to 6:00PM] [Friday, June 3 2022 8:00AM to 6:00PM]*

All Commercial Vendors must be 100% moved in and set up by 10:00AM on opening day. Commercial Vendors of spas, sunrooms, automobiles, boats, storage sheds, or any other large booths located in Expo Hall must make arrangements with the Fair Department to install their booths. Commercial Vendors are responsible for the complete installation and disassembling of their own displays. Please plan accordingly. **Gasoline or diesel-powered vehicles will be restricted on the show floor during load-in.** *\*if you arrive after fair opens you will not be allowed to set up*

## Load out

The fair is closed to the public at 10:00PM. The Carnival closes at 11:00PM. However, Fair Management reserves the right to close the Fair or Carnival earlier or later. Vendors may only dismantle after 10:00PM on the last Sunday of Fair. Any Vendor who dismantles before 10:00PM will then forfeit their

right to return to the Fair the next year. To allow for public safety, **vehicles will be prohibited from driving onto the grounds for a minimum of one-half hour after official carnival closing on Sunday, June 12, 2022.**

*The San Mateo County Exposition & Fair Association cannot be held responsible for any items left beyond 2:00am closing night of the Fair.*

The Commercial Vendor Building (Expo Hall) will be **closed at 2:00am** on closing night and all vendors must exit at that time. **Vehicles are prohibited from driving into commercial vendor building (Expo Hall) on closing night.** If you require access into the Commercial Vendor Building, you may enter the building at 9:00am on Monday, June 13<sup>th</sup>, 2022. **All merchandise inside Expo Hall must be removed prior to 10:00am on Monday, June 13<sup>th</sup>, 2022.** Gasoline or diesel-powered vehicles will be restricted on the show floor during load-out.

*\*any merchandise or booth set-ups still in Expo Hall after 10:00am on Monday, June 13<sup>th</sup> 2022 is subject to be thrown out or donated.*

X Initial \_\_\_\_\_

## M

### Megan's Law

You, all employees and volunteers eighteen (18) years of age or older who will be working at the San Mateo County Fair must be listed on the Megan's Law Form. By signing this form, you verify that everyone listed has been cleared. For more details, see Employee Guidelines

### Menus and Pricing

If your operation requires a menu, it must be easily visible and readable from the front of your stand. **No hand written menus are allowed.** You must also clearly display any special promotion(s) and signs required by the County Health Department. All menus must be submitted in advance to the Commercial Vendors Office. Each menu must include a list of items for sale and their prices. All prices **must include** the current **California State Sales Tax (9.5%)**. Sales taxes are subject to change.

Soft drinks and other beverages must comply with standard prices and portions as approved by the Fair. If we determine that any price or portion appears inadequate or unreasonable, you will be advised and given the opportunity to justify prices and portions, subject to Commercial Vendor Department approval. Failure to comply with these financial reporting procedures will be considered a violation of your Agreement. If a violation is so severe that it must be dealt with immediately, Fair Management will be called upon to review the situation and decide what action must be taken. Violations will be taken into consideration when reviewing applications for future San Mateo County Fairs or may result in immediate cessation of the right and privilege to do business with the San Mateo County Fair.

### Merchandise

The Fair **does not grant product exclusivity to any vendor participating** in the Fair unless such exclusive rights were granted through a specialized contracting process - such as major sponsorships or competitive bidding. For the mutual benefit of our vendors and the public we do make every attempt to diversify products by not over-booking product lines. The Fair makes the best selection possible from available applications. Selection is based upon product, presentation, references, and whether the product fits within the Rules and Regulations adopted by the Fair.

### Monetary Change

The San Mateo County Fair does not provide monetary change services. Please see below a list of the nearest banks:

**Wells Fargo** (650) 341-8751: 2950 El Camino Real, San Mateo, CA 94403.

**Bank of America** (650) 358-4454: 2900 S El Camino Real, San Mateo, CA 94403.

**Chase** (650) 345-0609: 1730 S El Camino Real, San Mateo, CA 94402

### Motorized Vehicles

Any motorized vehicle that is part of your display must be approved by the San Mateo County Fair in advance and remain in place during the entire nine day run of the Fair. If you are exhibiting vehicles powered by internal combustion gasoline engines inside buildings please follow these guidelines:

- Gasoline must be drained from the tank allowing only enough fuel (1/4 tank or 5 gallons – whichever is less) to enable the vehicle to drive in and out of the building.
- To deter removal, gas caps must be taped in place.
- Batteries must be disconnected.
- Battery terminals must be taped with electrical tape.
- Vehicles must be inspected by County Fair Management.
- Vehicles must be available for inspection by the Fire Marshal.
- 

## N

### Non-Profit

Non-profit organizations are reviewed and considered for acceptance based on the primary premise that they are promoting their organization's benefits

and their relation to the community. Applicants must also complement the Fair's vision of being an asset and resource for the community. Non-Profit Organization space and cost will be determined by Fair Coordinator. The Fair Association has sole discretion to accept or reject any vendor not limited to commercial vendors, concessionaires, non-profits, and fundraising organizations.

## O

### Offensive Items

We reserve the right to prohibit the sale, rental or display of any item that we reasonably deem objectionable from the standpoint of taste, quality, or compatibility with the San Mateo County Fair. Please note that we will not exercise this right for the purpose of controlling the economic return or to protect exclusive licensing or similar arrangement between Fair management and others. Some items that will not be considered for sale, giveaway or rental include, but are not limited to: weapons of any kind, lasers, high-powered water guns, rubber band guns, toy guns, products made from any endangered animals, pornographic or drug-related items, or any items displaying the Confederate flag.

## P

### Payments

Full payment is encouraged and preferred. However, 25% of the base cost is non-refundable and required with a copy of the signed agreement for space reservation (other fees may apply). Balance due is payable on or before the deadline date stated in the contract. Failure to pay on time will result in cancellation of the contract by Fair Management. *No checks will be accepted after May 13, 2022. Cash, money order, Visa/MasterCard/American Express, or cashier's check only will be accepted after this date payable to San Mateo County Fair.* **Any payments made after June 4, 2022 for the 2022 Fair will incur a \$50.00 service fee.**

A **\$25.00** administrative fee will be charged for **lost contracts or for any check returned** for any reason. A **\$75.00** administrative fee will be charged for approved contract changes. Vendors shall pay all required fees, taxes, and deposits and shall be responsible for other city, county, and state permits and licenses required by law.

### Plastic Bags

A county ordinance prohibits any commercial vendor from providing single-use plastic bags to customers. You MUST charge **\$0.25** reusable & paper bags. You can read the entire ordinance at <http://smchealth.org/BagBan>. Please plan accordingly to comply with this regulation.

### Power Conservation

Power conservation is mandatory and Fair staff will be monitoring everyone for compliance. Violators will have their power cords disconnected, so please be sure to follow these guidelines:

- All lights and other non-essential equipment must be turned off when the Fair closes each day.
- Outside lights must remain off until 7:00pm nightly.
- Only one hot tub or spa will be allowed to heat water with land power.
- Fair staff may ask you to disconnect any/all items occupying an electrical outlet at any time.

## R

### Rain

In the unlikely case of rain or heavy winds, all outside stands and booths may cover up to protect merchandise. Once the rain or wind stops, you will need to immediately remove the covers and re-open your operation for the rest of the day.

### Refund

The 25% deposit is **NON-REFUNDABLE**. Within 30 days to the Fair, any paid fees to the San Mateo County Fair are non-refundable.

### Returned Checks

A **\$25.00** administrative fee will be charged for any check returned for any reason. Returned checks must be paid by cash, certified check, money order, credit card or cashier's check within **10 days** of returned check. If you write a check that is returned for any reason, your check-writing privileges will be lost.

### Restocking

Expo Hall **east doors** will open one hour prior to the start of Fair each day for restocking purposes. The doors will open no earlier for security reasons unless it is setting up for an interim event.

## RV Accommodations

There are a limited number of spaces with water, sewer, and electrical hookups available on site. Spaces will be allocated by staff and must be paid for in advance. These spaces are for motor homes and trailers only. No camping tents are allowed on San Mateo County Event Center grounds. RV Space Application Form and payment must be returned to make your request for reservation. The Event & Parking Supervisor will determine the location and changes if needed. A request for stock truck storage must be made in advance of the Fair. Dead storage location will be determined upon arrival.

### RV, Stock Truck Fees:

- \$250.00/space – Stock Truck without Electrical
- \$350.00/space – Stock Truck with Electrical
- \$400.00/space – RV/Motor Home

One season auto parking pass will be issued per RV space. These are for vehicles in the RV area only.

Portable dump stations for grey water will be available. A “pump truck” is scheduled for those spaces that do not have sewer hook-ups during the Fair. There will be a complimentary pumping scheduled for those spaces that do not have a sewer hook-up. If you need additional services, please call American Debris Box **1-866-332-7471** to make an appointment. Restrooms are available during scheduled hours only. *\*Hours are subject to change\**  
**Please contact Nesh Pal, Parking & RV Supervisor, at 650-574-3247 Ext 345.**

## S

## Sales Tax

As of January 2021 Sales Tax in San Mateo is 9.5%.

## Screens and Fencing

Any booth or concession stand must be completed with visual screening to hide any approved service and storage areas from the public view. Screens and fencing are to be provided by commercial vendor or concessionaire and should be designed to match the artwork and colors of the booth, concession stand or trailer it is attached to. They must completely block any view to the entire back/side service and storage area of your booth, food stand or trailer. All trailers must have proper skirting around the perimeter to hide the under carriage, wheels or chassis and trailer hitch.

## Security

**Never leave your booth or stand unattended at any time during operating hours.** You should also make sure to cover all valuable items when leaving your booth at closing each evening. When leaving your booth each evening, please remove, cover up, and/or secure any valuable items. Valuable items that are small and portable, such as laptops, cell phones, DVD players, cameras, etc., should be removed from your booths. For the protection of all items within the facilities buildings and outside grounds, Security guards will be on duty from 10:00pm until the buildings open to the public the following day. Losses or infractions must be reported to the Commercial Vendor Office and Security immediately upon detection. Roving security will be on duty near the RV parking during "open" Fair hours only. **Management will not be responsible for lost, damaged, or stolen merchandise.**

## Smoking

Smoking is only permitted in designated areas, which means smoking in food preparation facilities, county buildings, reception areas, hallways, entrances, or bathrooms is not allowed at any time. This rule also applies during load-in and load-out days. Please refer to Fair maps for the Designated Smoking Tents.

## Solicitation

All solicitations and/or distribution of advertising material **MUST be confined to the area of the booth.** Any solicitations outside the confines of your assigned booth space can result (i.e. Roving Solicitation) in your expulsion from the Fair and forfeiture of all fees. Any violations will follow the **violation notice protocol** and the representative at the booth will be reminded of the policy. **Vendors receiving violations run the risk of not being permitted back to the San Mateo County Fair.**

## Sound Devices Pitches & Microphones

All microphones and music are subject to approval by the San Mateo County Fair and will be controlled so they do not interfere with the public or your neighboring exhibitors and concessionaires. Please be considerate of your neighbors and do not yell or call out to fairgoers to cross the aisle.

Should a Fair representative request that the volume of music, sound or noise be lowered or turned off at any time, concessionaire/merchant must immediately comply with request. Furthermore, bull horns or similar devices are not allowed.

## Space Location

Locations are assigned based on space availability. They are also determined in order of receipt of the vendor application and the order of contracting on a first-come, first serve basis. Communicability between the Fair and the vendor may affect the order in which space is assigned.

## Staffing

See **Employee Guidelines**



## State Sellers Permit

Vendors selling at the Fair must have a State Seller's Permit Number. For more information on how to obtain a Seller's Permit, visit: <http://www.boe.ca.gov/sutax/sutprograms.htm> In addition, you must include the San Mateo County Fair as a sub-location: San Mateo County Fair, 2495 S. Delaware Street, San Mateo, CA 94403. Please note that you MUST have your seller's permit number displayed in your booth/stand at all times and you may be subjected to an evaluation by the California State Board of Equalization.

## Storage

The San Mateo County Fair does not provide storage. Commercial Vendors and Food Concessionaires will need to make arrangements at their own expense. All excess boxes, cartons, crates, pallets, spa covers, and/or merchandise must be in your booth or rented outside area and out of public view. Storage for equipment not being used during the Fair is available on a limited basis and must be arranged in advance. Fees are dependent on space and services needed. If you have any vehicles, trailers, hitches, etc. which are not needed during the nine days of the Fair, arrangements must be made in advance to rent an area in our secure storage lot during the Fair. If the equipment is found parked at any other location on the fairgrounds without an appropriate parking credential, it will be towed at the owner's expense. The San Mateo County Fair assumes no liability for stored equipment, though the area is fenced in and within our parking lot. For more information contact the Fair Department.

## SUB-LEASING

Your assigned space is for your sole, exclusive and personal use. Commercial Vendors and Food Concessionaires are not allowed to sub-lease or allow any person or business to use your contracted space unless granted written permission by the San Mateo County Fair. If the approved sub-lease is doing business under a fictitious name or as a partnership or corporation, one individual of the business must be designated as the responsible party. The individual is the only one who can enjoy the privileges of conducting business, displaying, giving, or receiving information at your location. If allowed, the sub-lease must comply with all Vendor requirements and rules.

# T

## Telephone Services

You may require a telephone line for a telephone or to utilize a fax or credit card machine in your booth/stand. Orders for temporary phone service must be made in advance to Fair Department.

## Tents & Canopies

If you choose to use your own tent or canopy, it must be approved by the Commercial Vendor Office prior to installation. Outdoors vendors will be provided canopy tents. NO tents, canopies, or awnings are allowed inside any buildings. Tent structures are not allowed for food services. Tent stakes are not to be used to anchor tents to the asphalt without prior approval. Any vendor found using tent stakes will be held liable for asphalt repairs. All tents erected without approval will be subject to removal.

# U

## Uniforms

All employees must be tastefully clothed at all times. While uniforms are not mandatory, they are highly recommended.

# V

## Vendor Office

- o **Location:** North West Corner of Expo Hall
- o **Office Hours:**

<b>Thursday</b>	8:00am – 6:00pm	<b>Wednesday</b>	11:00am – 8:00pm
<b>Friday</b>	8:00am – 8:00pm	<b>Thursday</b>	11:00am – 8:00pm
<b>Saturday</b>	10:00am – 8:00pm	<b>Friday</b>	11:00am – 8:00pm
<b>Sunday</b>	10:00am - 8:00pm	<b>Saturday</b>	10:00am – 8:00pm
<b>Monday</b>	11:00am – 8:00pm	<b>Sunday</b>	10:00am – 8:00pm
<b>Tuesday</b>	10:00am – 8:00pm	<b>Monday</b>	8:00am- 10:00am

*\*Hours are subject to change\**

## Violation Notice

If you violate any part of this Handbook, a notice of violation will be issued. You will first receive a verbal warning and a reasonable amount of time to correct the violation. If the violation is not corrected, the verbal warning will be followed by a written notice of violation. The original copy will be given to you and a duplicate will be placed in your file along with a notation of the prior verbal warning. You will be given 24 hours to correct the violation. If the matter is not resolved, further action will be taken, as deemed appropriate by Fair management. Further action will include, but is not limited to: A second written notice of violation and an imposition of a **\$100.00 fine** to be paid immediately upon presentation of the written violation notice, with copies placed in your file; not being allowed in future Fairs; and an order to cease operation immediately and vacate the premises.

**W**

## Western Fairs Association

Western Fairs Association (WFA) cards are accepted as admission at all gates. To take advantage of this program you need to be a member of the WFA. Membership applications can be obtained by contacting WFA via phone at **916.927.3100** or through their website: [www.fairsnet.org](http://www.fairsnet.org)

## Wi-Fi

Direct internet and wireless internet is available throughout the grounds and may be purchased from the San Mateo County Fair. The order form can be found on the Vendors & Sponsors page on [www.SanMateoCountyFair.com](http://www.SanMateoCountyFair.com).

Please sign to acknowledge you have read and understand the San Mateo County Fair Rules and Handbook.

Your signature here also acknowledges that you have read and understand the 2022 Health & Safety Policy.

**Business Name** \_\_\_\_\_

**Print** \_\_\_\_\_ **Sign** \_\_\_\_\_

**Date** \_\_\_\_\_

NOTES: